

(314) 832-4500
Telex 44-2310

Essex Precision Controls, Inc.
8213 GRAVOIS AVENUE • ST. LOUIS, MO. 63123

ESSEX PRECISION CONTROLS, INC.

K-1248-6-3

BOEING P/N 60B00232-1

OVERHAUL AND PARTS LIST

IN-LINE CHECK VALVE

NOTE: This manual super-
cedes the Kohler manual dated
October 14, 1968

29-11-01
Page 1 of 1
January 20, 1977



(314) 832-4500
Telex 44-2310

Essex Precision Controls, Inc.

8213 GRAVOIS AVENUE • ST. LOUIS, MO. 63123
K1248-6-3

BOEING P/N 60B00232-1
OVERHAUL AND PARTS LIST

IN-LINE CHECK VALVE

TABLE OF CONTENTS

<u>SUBJECT</u>	<u>PAGE</u>
Description and Operation	1
Disassembly	1
Cleaning	1
Inspection	2
Repair	2
Assembly	2
Fits and Clearances	3
Testing	3
Trouble-Shooting	3
Storage Instructions	4
Special Tools, Fixtures & Equipment	4
Illustrated Parts List	4

29-11-01
Table of Contents
Page 1
Jan. 20/77



Essex Precision Controls, Inc.

8213 GRAVOIS AVENUE • ST. LOUIS, MO. 63123

K1248-6-3

BOEING P/N 60B00232-1
OVERHAUL AND PARTS LIST

IN-LINE CHECK VALVE

Model No. K1248-6-3

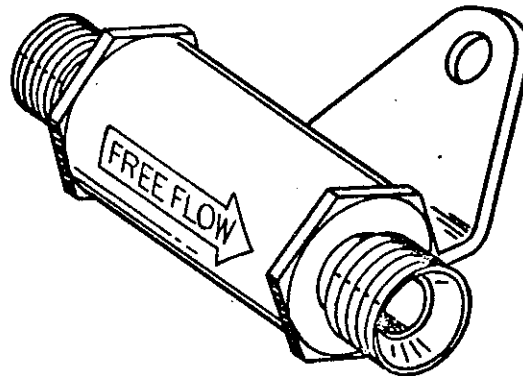

In-Line Check Valve

Figure 1

1. Description and Operation. (See Figure 1.)
 - A. The in-line check valve a spring loaded poppet type. This valve is used in the Hydraulic Plumbing System.
2. Disassembly. (See Figure 2.)
 - A. Remove cap (5) from sub-assembly (1).
 - B. Remove and discard O'ring seal (4).
 - C. Remove spring (3).
 - D. Carefully remove disk (2) to avoid scoring or scratching body (1).
3. Cleaning.
 - A. Wash all parts in Stoddard Solvent (P-S-661), or equivalent. Drain or blow off cleaning solvent with dry, filtered, compressed air.

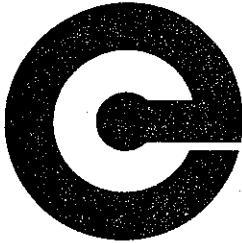

Essex Precision Controls, Inc.

8213 GRAVOIS AVENUE • ST. LOUIS, MO. 63123

K1248-6-3

BOEING P/N 60B00232-1
OVERHAUL AND PARTS LIST

IN-LINE CHECK VALVE

4. Inspection. (See Figure 2.)
 - A. Inspect all threads for stripping or other damage.
 - B. Inspect spring (3) for set condition. A force of 6.4 ounces \pm .64 ounce shall compress the spring to a height of 0.428 inch.
 - C. Inspect cap (5), disk (2) and body sub-assembly (1) for cracks, scores, nicks, abrasions or burrs.
 - D. Inspect valve seat in body sub-assembly (1) to ensure presence of sharp seating edge.
 - E. Inspect disk (2) for unusual wear patterns.
5. Repair. (See Figure 2.)
 - A. Repair minor thread damage by chasing.
 - B. Replace spring (3) if it does not meet inspection limits specified in Paragraph 4.B.
 - C. Repair minor damage to cap, disk and body by removing high metal, blending and polishing. Disk must fit into body with a smooth movement. No binding is permitted. If parts bind after repair, replace disk.
 - D. Worn valve seat in body sub-assembly may be machined to restore sharp-edged seat, free of nicks and burrs.
 - E. Disk seating surface may be refinished to remove minor depressions.
 - F. O'ring (4) must be replaced each time valve is repaired.
6. Assembly. (See Figure 2.)
 - A. If seat in body sub-assembly (1) or seating surface on disk (2) were repaired. The mating seating surfaces should be lapped together, using Grade 38-1200 compound United States Products Co., Pittsburgh, PA. or equivalent for 45 seconds. Clean parts per Paragraph 3.A.



Essex Precision Controls, Inc.

8213 GRAVOIS AVENUE • ST. LOUIS, MO. 63123

K1248-6-3

BOEING P/N 60B00232-1
OVERHAUL AND PARTS LIST

IN-LINE CHECK VALVE

- B. Place body sub-assembly (1) in suitable holding fixture. Locate body so that flow arrow is pointing upward.
 - C. Place disk (2) in body sub-assembly (1).
 - D. Place spring (3) in body sub-assembly (1) on top of disk (2).
 - E. Place new O'ring (4) on cap (5).
 - F. Screw cap (5) onto body sub-assembly (1) torque to 25-30 lb-ft.
7. Fits and Clearances. Not applicable.
8. Testing.
- A. Test Equipment Requirements.
 - (1) One 0-15 psig hydraulic gage, accurate to within ± 1 percent.
 - (2) One 0-5000 psig hydraulic pressure gage, accurate within ± 1 percent.
 - (3) Source of supply Skydrol 500 hydraulic fluid 0-4500 psig.
 - B. Cracking Pressure Test. Slowly apply pressure to the valve inlet. The valve shall open at pressure of 2-8 psig.
 - C. Leakage Test External. Apply pressure to 4500 psig to outlet of valve. No permissible external leakage allowed.
 - D. Leakage Test Internal. Apply pressure to 2000 psig to outlet of valve, hold for 3 minutes. No internal leakage allowed.
9. Trouble-Shooting.
- A. No special trouble-shooting procedures are required. If valve does not pass test, it must be disassembled, re-inspected for faulty parts or assembly techniques, re-assembled and re-tested.

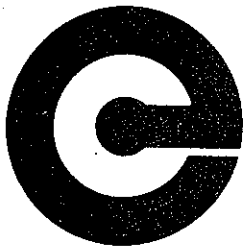

(314) 832-4500
Telex 44-2310

Essex Precision Controls, Inc.
8213 GRAVOIS AVENUE • ST. LOUIS, MO. 63123

K1248-6-3
BOEING P/N 60B00232-1
OVERHAUL AND PARTS LIST

IN-LINE CHECK VALVE

10. Storage Instructions.
 - A. Drain excess test fluid from the valve.
 - B. Cap ports with suitable caps, wrap in heavy packing paper and package in cardboard carton.
11. Special Tools, Fixtures and Equipment. None required.
12. Illustrated Parts List.

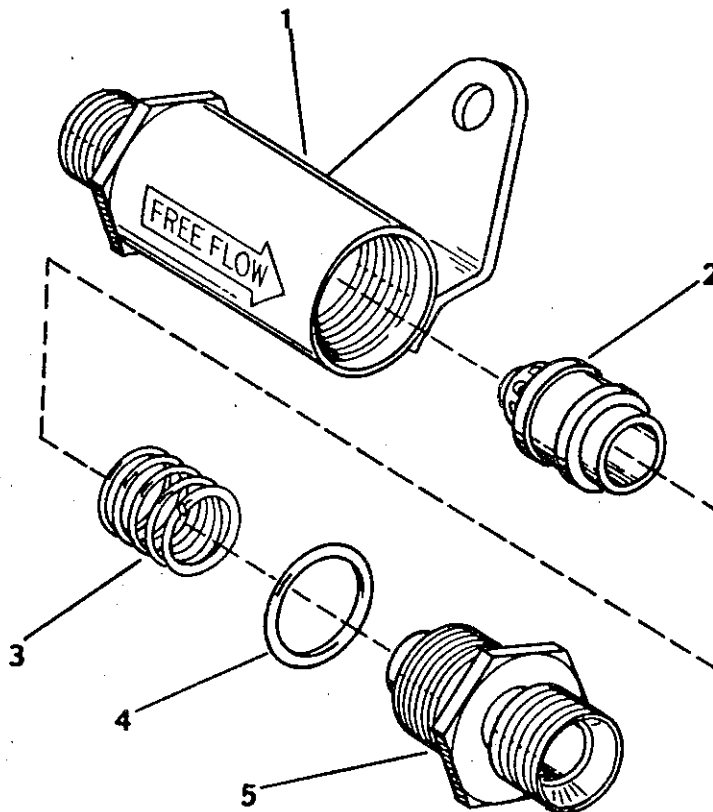

Exploded View - In-Line Check Valve

Figure 2

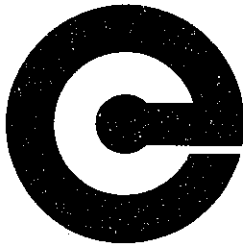

(314) 832-4500
Telex 44-2310

Essex Precision Controls, Inc.
8213 GRAVOIS AVENUE • ST. LOUIS, MO. 63123

K1248-6-3
BOEING P/N 60B00232-1
OVERHAUL AND PARTS LIST

IN-LINE CHECK VALVE

FIG.	ITEM	PART NUMBER	NOMENCLATURE						EFFECT FROM TO	UNITS PER ASSY.
			1	2	3	4	5	6		
2		K1248-6-3	VALVE, In-Line, Check							RF
	1	A8627	Body Sub-Assembly							1
	2	A2002	Disk							1
	3	A208	Spring							1
	4	NAS1611-112	O'Ring							1
	5	A3759	Cap							1